

OX03A10 2.46MP product brief



available in
a lead-free
package

Industry-Leading Low-Light Performance and High Dynamic Range for a Wide Range of Automotive Applications

OmniVision's OX03A10 is a high-performance, low-power 3.2 micron OmniBSI-2™ image sensor designed for a wide range of advanced automotive imaging applications, including 360-degree surround view, rear view, blind-spot detection, e-mirror, and lane departure warning.

The 2.46 megapixel sensor uses OmniVision's proprietary Deep Well™ pixel technology to deliver industry-leading low-light sensitivity, and enables up to 90 dB of high dynamic range (HDR) from a single exposure without any decrease in signal-to-noise ratio and without motion artifacts. The OX03A10 also features dual-exposure HDR mode that can extend the sensor's dynamic range to more than 120 dB.

The OX03A10 can output multiple resolution formats, including 1920 x 1280 resolution video at 50 frames per second (fps) and 1920 x 1080 resolution video at 60 fps.

The sensor comes in an AEC-Q100 Grade 2-qualified 8.0 x 7.2 mm chip-scale package or 10.0 x 9.0 mm ball grid array package and has been developed according to ISO 26262 ASIL B requirements.

Find out more at www.ovt.com.



Applications

- Automotive
 - 360° Surround View System
 - Rear View Camera
 - Lane Departure Warning/ Lane Keep Assist
- Camera Monitoring System/e-mirror
- Autonomous Driving

Product Features

- support for image size:
 - 1920 x 1280
 - 1920 x 1080
 - VGA
 - QVGA, and any cropped size
- high dynamic range
- high sensitivity
- image sensor processor functions:
 - defective pixel cancelation
 - HDR combination
 - automatic black level correction
 - PWL compression, etc.
- pixel data: 12b RAW RGB
- SCCB for register programming
- dedicated safety features for supporting minimum ASILB applications
- programmable GPIOs
- high speed serial data transfer with MIPI CSI-2
- external frame synchronization capability
- embedded temperature sensor
- one time programmable (OTP) memory

OX03A10



Ordering Information

- OX03A10-E80Y-1B-Z**
(color, lead-free, 80-pin a-CSP™, packed in tray without protective film)
- OX03A10-E80Y-0B-Z**
(color, lead-free, 80-pin a-CSP™, packed in tape & reel with protective film)
- OX03A10-E80Y-LB-Z**
(color, lead-free, 80-pin a-CSP™, packed in tray with protective film)
- OX03A10-B83Y-1B-Z**
(color, lead-free, 83-pin a-BGA™, packed in tray without protective film)
- OX03A10-B83Y-0B-Z**
(color, lead-free, 83-pin a-BGA™, packed in tape & reel with protective film)
- OX03A10-B83Y-LB-Z**
(color, lead-free, 83-pin a-BGA™, packed in tray with protective film)

Product Specifications

- active array size:** 1920 x 1280
- power supply:**
 - analog: 3.3V
 - digital: 1.2V
 - I/O pads: 1.8V
- power requirements:** active - streaming @ 1280p50/1080p60: 370 mW (typical use-case)
- temperature range:**
 - operating: -40°C to +105°C sensor ambient temperature and -40°C to +125°C junction temperature
- output interfaces:** up to 4-lane MIPI CSI-2
- input clock frequency:** 6 - 36 MHz
- lens size:** 1/2.44"
- lens chief ray angle:** 19.7°
- SCCB speed:** up to 1 MHz
- scan mode:** progressive
- output formats:** single exposure HDR - 16-bit combined RAW, 12-bit (PWL) compressed combined RAW; dual exposure HDR - 16-bit combined RAW + 12-bit VS RAW, 12-bit (PWL) compressed combined RAW + 12-bit VS RAW
- shutter:** rolling shutter
- maximum image transfer rate:**
 - 1080p: 60 fps
 - 1280p: 50 fps
- sensitivity:** 35000 e-/Lux.s (green pixel response at 530 nm illumination)
- max S/N ratio:** 45.4 dB
- dynamic range:**
 - 90 dB single exposure HDR
 - >120 dB dual exposure staggered HDR
- pixel size:** 3.2 μm x 3.2 μm
- image area:** 6195.2 μm x 4147.2 μm
- package dimensions:**
 - a-CSP™: 8034 μm x 7210 μm
 - a-BGA™: 10 mm x 9 mm

Functional Block Diagram

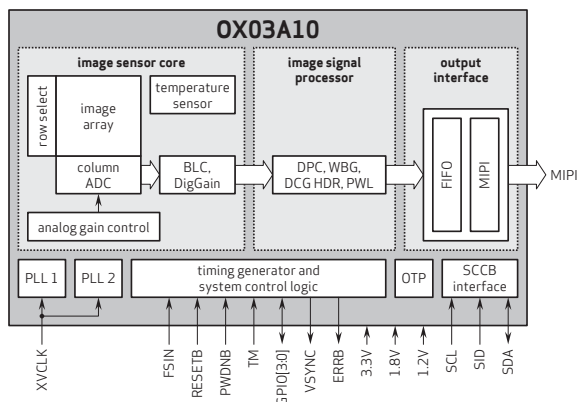

4275 Burton Drive
Santa Clara, CA 95054
USA

Tel: + 1 408 567 3000
Fax: + 1 408 567 3001
www.ovt.com

OmniVision reserves the right to make changes to their products or to discontinue any product or service without further notice. OmniVision and the OmniVision logo are registered trademarks of OmniVision Technologies, Inc. OmniBSI-2, a-CSP, a-BGA, and Deep Well are trademarks of OmniVision Technologies, Inc. All other trademarks used herein are the property of their respective owners.



OmniVision